



LASER MARKING



AREX: LASER MARKING MADE EASY

The AREX Series is a multi-functional and all inclusive line of fiber laser markers dedicated to direct part marking in the Automotive, Electronics, and precision mechanics industry. Thanks to its ultra-compact scanhead, flexible marking platform and advanced software features, AREX laser marker provides a flexible, reliable, cost effective solution for permanent and indelible high quality marking directly on your production line. AREX laser markers are equipped with high performance pulsed fiber laser sources with power levels from 10W to 50W and with the new 20W MOPA fiber source based on the proprietary MULTIWAVE fiber laser technology for maximum control of laser emission. The AREX series offers more than just a laser marker. AREX's Embedded Marking Controller simplifies setup, configuration and management of single or multiple laser markers, both in stand-alone or in master-slave configuration. The AREX Series is a simple and complete solution for any laser marking application.

APPLICATIONS

- METAL MARKING**
- AREX fiber laser marker series provides unmatched performance and functionality on metal
 - High resolution, excellent contrast with low thermal impact
 - Quick and clear black laser annealing, without cracks
 - High quality deep engraving
- HIGH CONTRAST MARKING**
- High contrast marking on color enhanced plastics
 - High speed on PCB and electronic devices



Quick installation and setup

AREX design and configuration dramatically simplifies and speeds up machine design and system integration.

- Embedded Marking Controller (EMC) with LIGHTER Suite ensures quick and easy installation, setup, control and system diagnostics, even remotely via Ethernet TCP/IP
- Ultra compact scan head (112x300x90mm) saves space and reduced costs during installation and setup
- Built-in step motor controller, completely integrated in software editor, dramatically simplifies integration of rotary indexers, x-y tables and z axis
- Front panel USB for quick and easy system update and layout transfer

Flexible programming and control

LIGHTER Suite, with its intuitive and easy-to-learn interface, simplifies the development of a complete and cost effective Laser Marking Station for OEM and Machine builders. AREX can be operated in a STAND ALONE MODE with built-in control and software resources, and in a MASTER-SLAVE mode with a supervising computer for advanced network-oriented Laser Marking Applications.

Main built-in features are:

- Advanced Graphical Layout
- Local and Remote laser diagnostic
- Local and Remote I/O & axis control
- Local and Remote laser test & setup
- Local and Remote ActiveX
- Ethernet protocol for easy integration PLC and industrial environments
- Marking On-the-Fly capabilities



AREX SERIES

		AREX	AREX 20	AREX 30	AREX 50	AREX 20MW
Nominal power	[W]	>10	>20	30	50	>20
Pulse energy (max)	[mJ]	0,5	1,0	1,0	1,0	0,6
Peak power (max)	[kW]	5	10	11	10	12
Modulation	kHz	20 ÷ 100		30 ÷ 200	50 ÷ 200	20 ÷ 500
Laser source		Pulsed Fiber Laser				M.O.P.A. Fiber Laser
Pulsewidth (Typ)	[ns]	FIXED: 100				Adj: 4, 8, 12, 30, 50, 100, 200, 250
Wavelength	[nm]	1050÷1080				
Marking capabilities		Static, Rotary axis, On the fly (marking in motion)				
Fiber length	[m]	3				
Integration		Up to 4 mechanical axis driving capabilities (built in stepper motors controller) Up to 10 digital inputs and 10 digital output fully programmable dedicated connectors Encoder and Photocell				
Aiming & Focus Beam		Semiconductor laser @ 635nm				
Interfaces		4 x USB, 1 x Ethernet, 1 x RS232, Digital I/O				
Protection rating		Head: IP54; Controller: IP 21				
Cooling		Forced air				
Power Supply		100/240 VAC – 50/60 Hz – 330 W (MAX)				
Head Dimensions & Weight		90mm x 112mm x 300mm – 3 kg				
Controller Dimensions & Weight		111mm x 430 mm x 370 mm – 16 kg				

AREX PULSED

MARKING MADE EASY

High performance and reliability

- Low leakage to avoid ghost lines or material damage even on sensitive materials
- High protection rate scanhead, IP54 for maximum performance even in aggressive environment
- Complete power range from 10 W to 50W
- Standard Datalogic I/O Interface
- Integrated Windows based marking controller, no external PC needed.
- Full Lighter Software included, no dongle needed
- Aiming Beam and Focus Beam
- RS232 and Ethernet protocol



INDUSTRIES

AUTOMOTIVE, INDUSTRIAL ELECTRONICS, PRECISION MECHANICS, SURGICAL TOOLS & IMPLANTS

APPLICATIONS

- High contrast marking & engraving for branding & traceability on: Stainless steel, high-grade steel, steel, carbon steel, copper, iron, ferrous metals, magnesium, aluminum, brass, gold, silver, platinum, titanium
- 'Aesthetic' plastic marking
Polycarbonate (PC) Polysulfone (PSU), Polyphenylene sulfide (PPS)
- 'Non- aesthetic' plastic marking for traceability
Polystyrene (PC), Styrene acrylonitrile (SAN), Acrylonitrile Butadiene Styrene (ABS), Polyethylene terephthalate (PET) Polybutylene terephthalate (PBT)
- Additivated plastic marking
Polyamide (PA), Polyoxymethylene (POM) Polypropylene (PP), Polyethylene (PE) and many other



AREX MW

FLEXIBLE LASER PERFORMANCE

High flexibility and marking repeatability

The AREX family delivers a high level of performance for high precision marking

Additional features:

- Linear power range from 0,1W to full power for precise marking even on sensitive materials
- Pulsewidth adjustment from 4 ns to 250 ns for best process optimization and repeatability
- High repetition rate up to 500KHz for faster marking and accurate texturing
- High peak power for extended process capability
- Standard Datalogic I/O interface



INDUSTRIES

AUTOMOTIVE, AEROSPACE, INDUSTRIAL ELECTRONICS, MOBILE & SEMICON ELECTRONICS, PRECISION MECHANICS, WATCH & JEWELRY, SURGICAL TOOLS & IMPLANTS

APPLICATIONS

- High precision contrast marking and annealing for branding & traceability on: stainless steel, high-grade steel, steel, carbon steel, iron, ferrous metals, magnesium, aluminum, brass, gold, platinum, titanium ...
- 'Aesthetic' plastic marking for branding and texturing Polycarbonate (PC) Polysulfone (PSU), Polyphenylene sulfide (PPS), Polyether ether ketone (PEEK)
- High contrast plastic marking for traceability Polystyrene (PS), Styrene acrylonitrile (SAN), Acrylonitrile Butadiene Styrene (ABS), Polyethylene terephthalate (PET) Polybutylene terephthalate (PBT) Polyoxymethylene (POM)
- Color enhanced plastic Polyamide (PA), Polypropylene (PP), Polyethylene (PE) and many other
- Coating removal/night & day application
- Color marking on metal



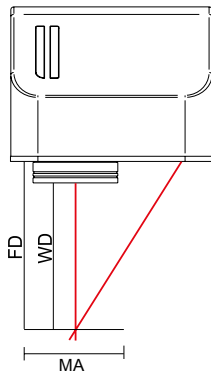

F-THETA MODEL	FIXING DISTANCE [FD]	WORKING DISTANCE [WD]	AREX 10 AREX 20 AREX 20MW	AREX 30 AREX 50
	mm	mm	MARKING AREA [MA]	MARKING AREA [MA]
			mm ²	mm ²
F100S	146	118	60 X 60	NA
F160S	197	183	100 X 100	NA
F254S	300	280	140 X 140	NA
F160L	212	176	110 X 110	100 X 100
F254L	367	296	180 X 180	170 X 170
F330L	471	388	220 X 220	210 X 210
F420L	575	494	285 X 285	NA

DIMENSIONS

CONTROL UNIT

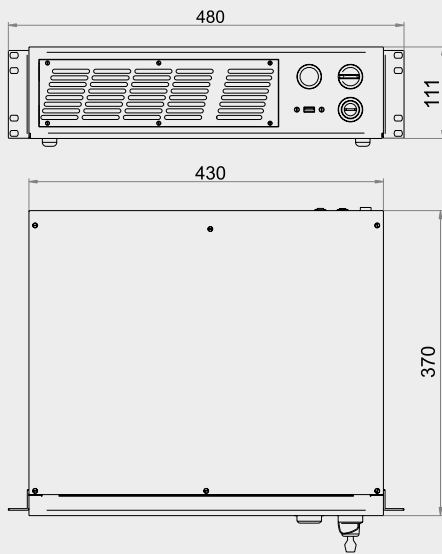

MARKING HEAD

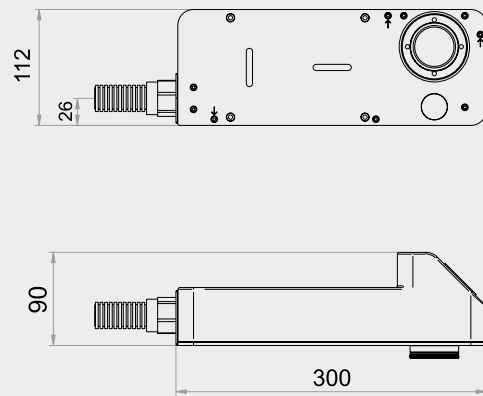

MODEL SELECTION AND ORDER INFORMATION

ORDERING CODES	MODEL	FULL DESCRIPTION
985180023	AREX 1100-1042 Fiber IR System	AREX 10W IR Fiber Marker w/out F-Lens
985180058	AREX 1100-1142 Fiber IR System	AREX 10W IR Fiber Marker F100S-M39 lens
985180027	AREX 1100-1342 Fiber IR System	AREX 10W IR Fiber Marker F160S-M39 lens
985180028	AREX 1100-1642 Fiber IR System	AREX 10W IR Fiber Marker F254S-M39 lens
985180069	AREX 1100-1742 Fiber IR System	AREX 10W IR Fiber Marker F254L-M85 lens
985180024	AREX 1200-1042 Fiber IR System	AREX 20W IR Fiber Marker w/out F-Lens
985180059	AREX 1200-1142 Fiber IR System	AREX 20W IR Fiber Marker F100S-M39 lens
985180029	AREX 1200-1342 Fiber IR System	AREX 20W IR Fiber Marker F160S-M39 lens
985180030	AREX 1200-1642 Fiber IR System	AREX 20W IR Fiber Marker F254S-M39 lens
985180051	AREX 1200-1742 Fiber IR System	AREX 20W IR Fiber Marker F254L-M85 lens
985180060	AREX 1200-1A42 Fiber IR System	AREX 20W IR Fiber Marker F330L-M85 lens
985180061	AREX 1200-1B42 Fiber IR System	AREX 20W IR Fiber Marker F420L-M85 lens
985180047	AREX A200-1053 MW Fiber IR System	AREX 20MW MOPA Fiber Marker w/out F-Lens
985180048	AREX A200-1353 MW Fiber IR System	AREX 20MW MOPA Fiber Marker F160S-M39 lens
985180049	AREX A200-1653 MW Fiber IR System	AREX 20MW MOPA Fiber Marker F254S-M39 lens
985180066	AREX A200-1753 MW Fiber IR System	AREX 20MW MOPA Fiber Marker F254L-M85 lens
985180067	AREX A200-1A53 MW Fiber IR System	AREX 20MW MOPA Fiber Marker F330L-M85 lens
985180068	AREX A200-1B53 MW Fiber IR System	AREX 20MW MOPA Fiber Marker F420L-M85 lens
985180063	AREX 1300-1442 Fiber IR System	AREX 30W IR Fiber Marker F160L-M85 lens
985180052	AREX 1300-1742 Fiber IR System	AREX 30W IR Fiber Marker F254L-M85 lens
985180053	AREX 1300-1A42 Fiber IR System	AREX 30W IR Fiber Marker F330L-M85 lens
985180064	AREX 1500-1442 Fiber IR System	AREX 50W IR Fiber Marker F160L-M85 lens
985180055	AREX 1500-1742 Fiber IR System	AREX 50W IR Fiber Marker F254L-M85 lens
985180056	AREX 1500-1A42 Fiber IR System	AREX 50W IR Fiber Marker F330L-M85 lens

Rev. 10, 04/2016

